

# ENERGY RECOVERY

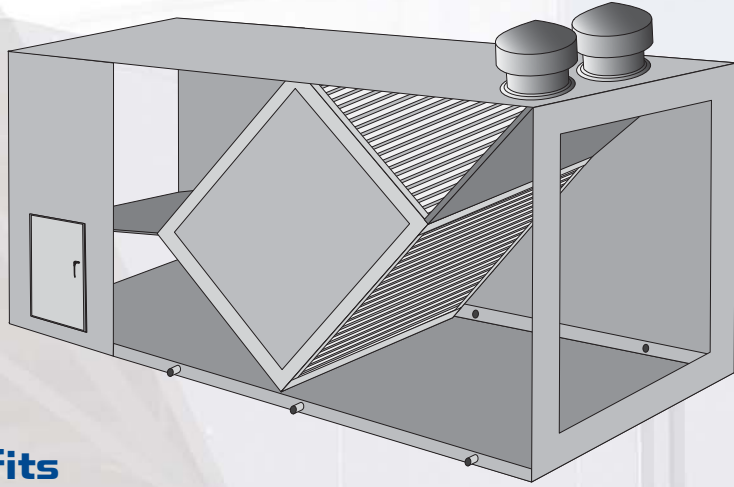

Modules for 4000-Series Direct-Fired Air Handlers



## Benefits

- **Energy Efficiency - Heating** - reduces fuel consumption by using warm exhaust air to pre-heat incoming outdoor air. For summer ventilation, diverts outside air around the energy recovery module.  
*Cooling* – uses exhausted cool air to pre-cool outdoor air, providing greatly enhanced year-round energy savings.
- **Frost-free Operation** - with the ability to operate at any temperature, ERM continually monitors interior temperature, modulates face and bypass dampers on the heat exchanger and prevents frost build up, while ensuring maximum energy recovery.
- **Reduced Carbon Footprint** – significantly reduces carbon dioxide (CO<sub>2</sub>)
- **Hygienic Operation** - exhaust air will not cross-contaminate supply air.
- **Durability** - no moving parts, strong aluminum plates in high standard alloy mean long lifetime and minimal service. The design allows for rapid, thorough cleaning and servicing.
- **Design Flexibility** - standard sizes for air flows up to 25,000 CFM (larger custom sizes available). Epoxy coated modules for highly corrosive environments like wastewater treatment plants (WWTP).

## How Energy Recovery Modules Work:

With a plate-style energy recovery module, exhaust air and incoming air pass each other in a cross-flow pattern, divided by thin metal plates. Sensible energy is transmitted from exhaust air to incoming air via conduction.



## Maximize Energy and Heat Recovery, Minimize Cost and Environmental Impact

# Applications

Energy recovery modules are beneficial for any building requiring make-up air. Process heat, can be reclaimed from exhaust air instead of being wasted. The greater the air volume or temperature of the exhaust air, the greater the potential savings.

- **All Types of Manufacturing**
  - **Automotive**
  - **Furniture**
  - **Textiles, clothing and other finished goods**
- **Warehouses**
- **Wood processing facilities**
- **Any building requiring make-up air**



- **Wastewater treatment plants (epoxy coated ERM sections)**
- **Paint spray booths**

# Specifications

**Plate Material:**  
Aluminum/ Epoxy

**Size:**  
19.69" – 118.1"

**Maximum differential pressure:**  
3000 Pa 12.04 "WC

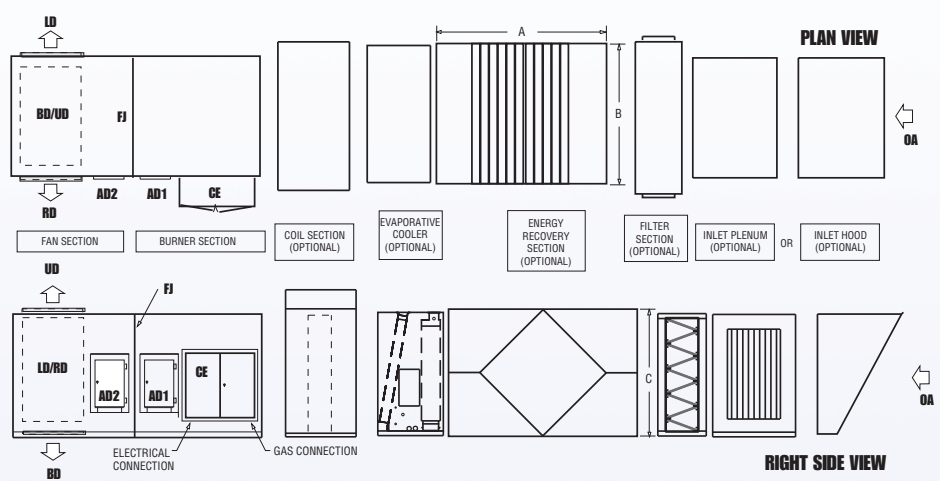

Applicable Model		Airflow - Cubic Feet per Minute (CFM)	Dimensions (in)			Estimated Weights (lb)					
MUA	AM		Length	Width	Height	Module	Inlet Hood	Exhaust Fan	Exhaust Hood	Downturn Section	Filter Housing
			A	B	C						
4024	4024	4,000-7,000	109	59	73	1,000	150	400	150	250	225
		7,001-15,000	120	85	98	1,900	200	550	200	450	425
		15,001-20,000	130	95	112	2,000	200	800	225	450	425
		20,001-25,000	137	95	127	2,700	300	800	250	550	475

Compatible Cabinet Size		Supply/Exhaust Air - Cubic Feet per Minute (CFM)	Pressure Drop (in wc)		Efficiency		Air Velocity Supply (face/channel) (ft/min)	
MUA	AM		Supply	Exhaust	Supply	Exhaust	Supply	Exhaust
4024	4024	4,000	0.42	0.45	59%	59%	329.19 / 851.18	367.34 / 889.82
		5,000	0.63	0.67	60%	60%	411.49 / 1,064.04	459.17 / 1,112.20
		6,000	0.88	0.94	59%	59%	493.79 / 1,276.74	551.01 / 1,334.75
		7,000	1.17	1.25	59%	59%	576.09 / 1,489.31	642.84 / 1,557.43
		7,001	0.29	0.30	63%	61%	240.04 / 632.20	267.85 / 658.93
		8,000	0.37	0.39	63%	61%	274.33 / 722.60	306.12 / 752.99
		9,000	0.45	0.48	63%	61%	308.62 / 812.94	344.38 / 847.09
		10,000	0.55	0.59	63%	61%	342.91 / 903.25	382.64 / 941.23
		11,000	0.66	0.70	63%	61%	377.20 / 993.53	420.91 / 1,035.40
		12,000	0.77	0.82	63%	61%	411.49 / 1,083.78	459.17 / 1,129.59
4036	4036	13,000	0.89	0.95	63%	61%	445.78 / 1,174.00	497.44 / 1,223.81
		14,000	1.03	1.09	63%	61%	480.08 / 1,264.21	535.70 / 1,318.05
		15,000	1.17	1.24	63%	61%	514.37 / 1,354.39	573.97 / 1,412.31
		15,001	0.70	0.74	62%	61%	403.43 / 1,021.84	450.17 / 1,065.94
		16,000	0.79	0.84	62%	60%	430.32 / 1,089.88	480.18 / 1,137.09
		17,000	0.88	0.94	62%	60%	457.22 / 1,157.91	510.19 / 1,208.25
		18,000	0.98	1.05	62%	60%	484.11 / 1,225.92	540.20 / 1,279.42
		19,000	1.08	1.16	62%	60%	511.01 / 1,293.92	570.22 / 1,350.60
		20,000	1.19	1.27	61%	60%	537.90 / 1,361.91	600.23 / 1,421.78
		20,001	0.72	0.77	62%	60%	457.22 / 1,130.29	510.19 / 1,179.84
4040	4040	21,000	0.79	0.85	61%	60%	480.08 / 1,186.72	535.70 / 1,238.92
		22,000	0.87	0.92	61%	60%	502.94 / 1,243.14	561.21 / 1,297.99
		23,000	0.94	1.00	61%	60%	525.80 / 1,299.55	586.72 / 1,356.99
		24,000	1.02	1.09	61%	59%	548.66 / 1,355.95	612.23 / 1,415.99
		25,000	1.10	1.17	61%	59%	571.52 / 1,412.35	637.74 / 1,474.99

## Written Specifications

**Energy Recovery:** A housed plate style energy recovery module is placed on the inlet side of the blower (blower/heated) section(s). The minimum energy transfer efficiency shall be 60% or above. Four access panels positioned at both the inlet and outlet locations of the module are used for cleaning/servicing of both exhaust and outside air streams. Cabinet floor shall incorporate drain pan(s) to remove condensate and assist with proper cleaning procedures. Supply and exhaust compartments include drain pan(s). Housing arrangement accepts a draw through exhaust fan provided by the [air handler manufacturer][by others]. Face and by-pass dampers mounted on the inlet side of the module are dynamically modulating to control frost prevention and economizer control. Traversing frost control is not acceptable.